

FAG 240SM400-MA参数

尺寸	d_2	462	mm	-
	r_{min}	5	mm	-
重量	m	313000	g	质量
基本额定载荷	C_r	3750000	N	基本额定动载荷，径向
计算系数	e	0.32		-
	Y_1	2.13		-
	Y_2	3.17		-
基本额定载荷	C_{0r}	8000000	N	基本额定静载荷，径向
计算系数	Y_0	2.08		-
极限转速	n_G	190	r/min	极限转速
疲劳极限载荷	C_{ur}	630000	N	疲劳极限载荷，径向
轴向许用载荷	$F_{a\ max}$	60000	N	轴向许用载荷，适用于 无轴向支撑的内圈
锁紧力矩	M_a	69	Nm	每个锁紧螺钉的锁紧力 矩
尺寸	d	400	mm	-
	D	620	mm	-
	C	200	mm	-
	B	290	mm	-
	D_s	546	mm	-

FAG 240SM400-MA图片

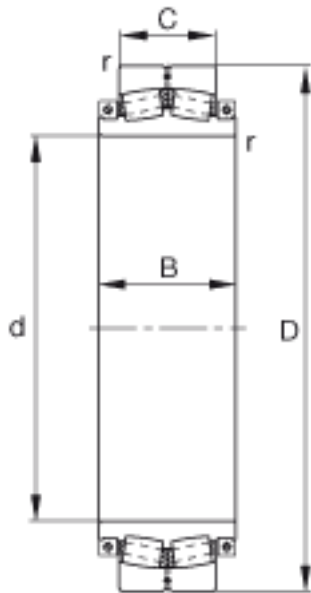
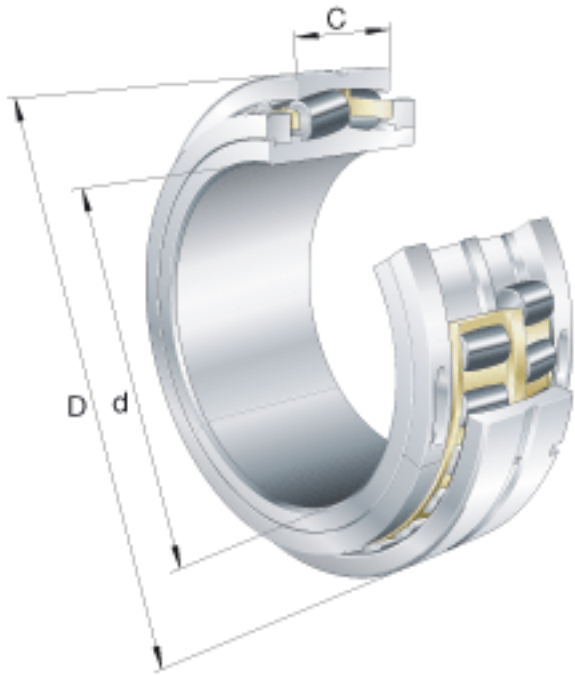

参考资料:<http://www.sozhou.com/p/9e50f631.html>